

# **SAMPLING NOTES**



# ***SAMPLING NOTES***

Copyright © 1964 by Tektronix, Inc.,  
Beaverton, Oregon. Printed in the United  
States of America. All rights reserved.  
Contents of this publication may not be re-  
produced in any form without permission  
of the copyright owner.

*Tektronix, Inc.*

S.W. Millikan Way ● P. O. Box 500 ● Beaverton, Oregon ● Phone MI 4-0161 ● Cables: Tektronix

## CONTENTS

	Page
Objective	1
Why Sampling Oscilloscopes	1
Pulse Definitions And Coaxial Cable Characteristics	1
Tektronix Sampling Systems	3
Risetime Controlled By Interrogate Pulse Duration	5
Loop Gain	5
Sampling Density	5
Dot Transient Response (Apparent Risetime Sampling Density Dependence)	5
Smoothing Of Random Noise	6
Changing Sensitivity	6
Adding a Dc Offset Voltage To The Signal	6
Getting The Signal To The Input	6
Probes For Sampling Systems	8
Sampling Timing Systems	8
References	12

# SAMPLING NOTES

## Objective

These sampling notes are offered as an aid to the user of Tektronix sampling systems. Concepts and systems are discussed, with references of some texts included for additional study.

## Why Sampling Oscilloscopes

The general need for sampling systems is caused by the normal gain-bandwidth limitations of amplifiers. The state of the electronic art has not advanced to the point where fractional-nanosecond low-level signals can be displayed directly. A sampling system looks at a small portion of a waveform, remembers the amplitude for as long as desired, and presents a display of the instantaneous amplitude, all without amplifying the signal directly. It looks at the waveform again slightly later in time, presents a new portion of the display, and ultimately shows a complete display in reconstructed form.

Fig. 1 illustrates the reconstruction of a repetitive square wave, showing that the crt display is a series of dots rather than the normal oscilloscope continuous presentation. In the illustration, a series of sampling pulses is superimposed on the input waveforms. The pulse samples, and not the actual input signal, are displayed by the oscilloscope. At the peak of each sampling pulse the crt of the oscilloscope is unblanked and a spot appears. A large number of such spots forms the display. The number of dots in a display is variable over a range of 50 to 500 or more, depending upon the particular instrument.

The sampling oscilloscope operates from repetitive signals, although not necessarily signals with a constant repetition rate. A small portion of each cycle of the signal is measured and a dot is displayed which indicates the amplitude of the sampled portion of the signal. The dot is horizontally positioned proportional to the point in time-space sampled.

Sampling systems (and conventional oscilloscopes) have a maximum operating repetition rate. Signals below this rate may have considerable repetition rate jitter and still be presented without appreciable display jitter. Signals above the maximum repetition rate will be "counted down". Only those repetitions occurring after the sampling system recovery

will be displayed. Since the signals are repetitive in character, the missed cycles are of no significance (as in conventional oscilloscopes).

## Pulse Definitions And Coaxial Cable Characteristics

Gaussian pulses amplified by a gaussian system take the general nature of Fig. 2. The performance of the system is known by measuring the 10% to 90% risetime of the output pulse when the input pulse 10% to 90% risetime is several times faster.

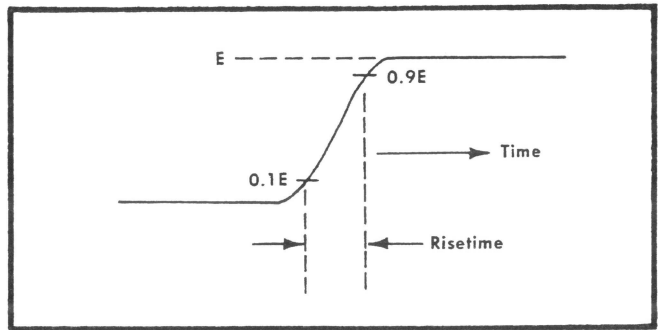

Fig. 2. Response of a gaussian amplifier to a gaussian pulse.

Pulses handled by transmission lines (such as for 50-ohm input sampling) are not treated in a gaussian manner. Fig. 3(a) represents the step-function response of transmission lines commonly used for pulse work having a decibel attenuation that varies as the square root of frequency.<sup>1</sup> The time,  $T_0$  (Tee Naught), is defined as the interval measured from the start of the output pulse to the point at which  $E_{out} = 0.5 E_{in}$ . Fig. 3(a) relates to coaxial lines with negligible dielectric loss. Good coaxial cables 10% to 90% risetime is usually about 30 times  $T_0$ . An interesting character of transmission lines is that an increase in length of 2 times increases  $T_0$  4 times (see Fig. 3(b)). Fig. 3 does not include effects that depend on the way in which the cable is used. Examples of such

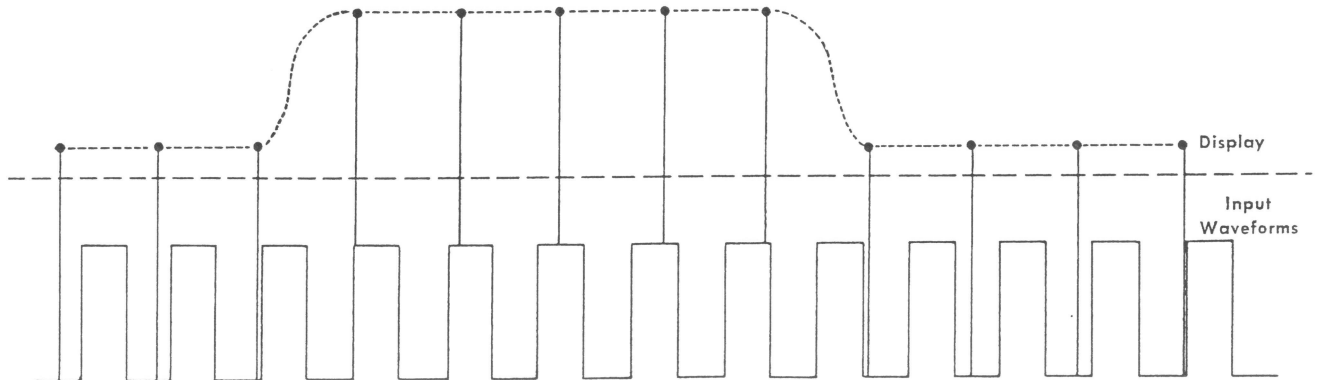

Fig. 1. Displaying input waveforms by means of the sampling technique.



Sampling Notes

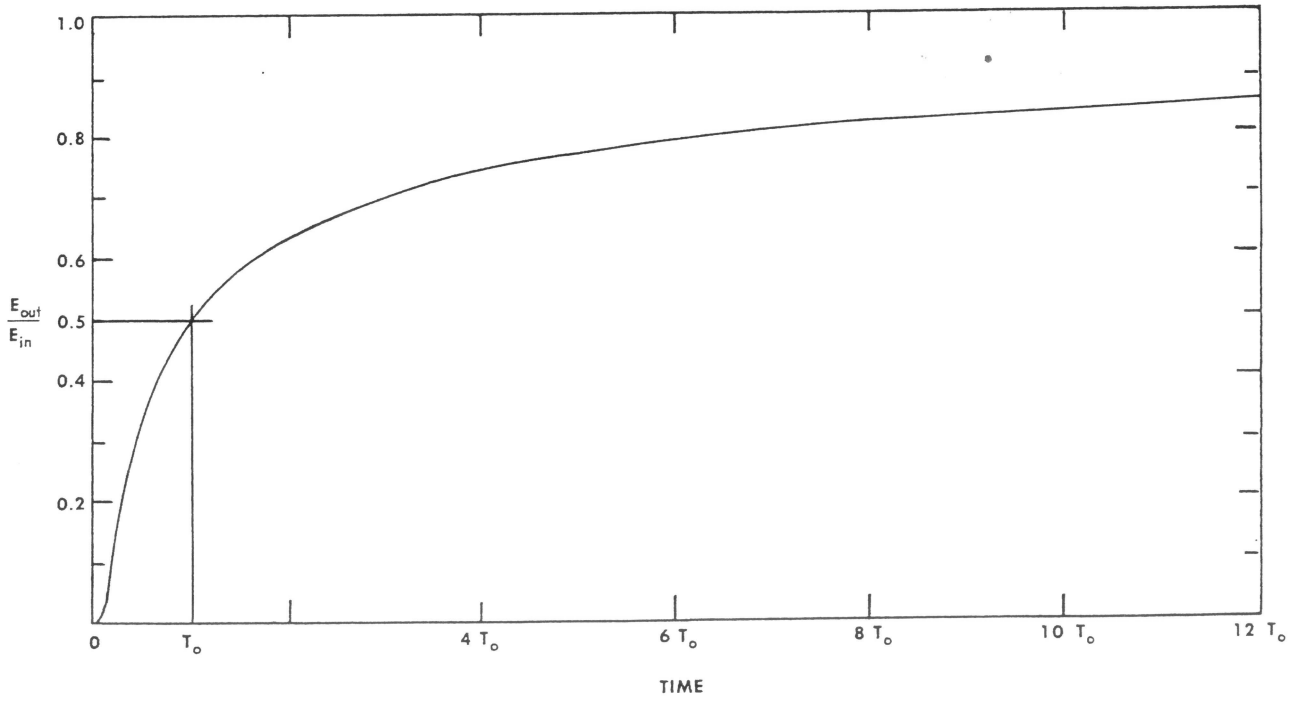

Fig. 3a. Step-function response of transmission lines for which decibel attenuation varies as the square root of frequency. The time  $T_0$  is defined as the interval measured from the start of the output pulse to the point at which  $E_{out} = 0.5 E_{in}$ .

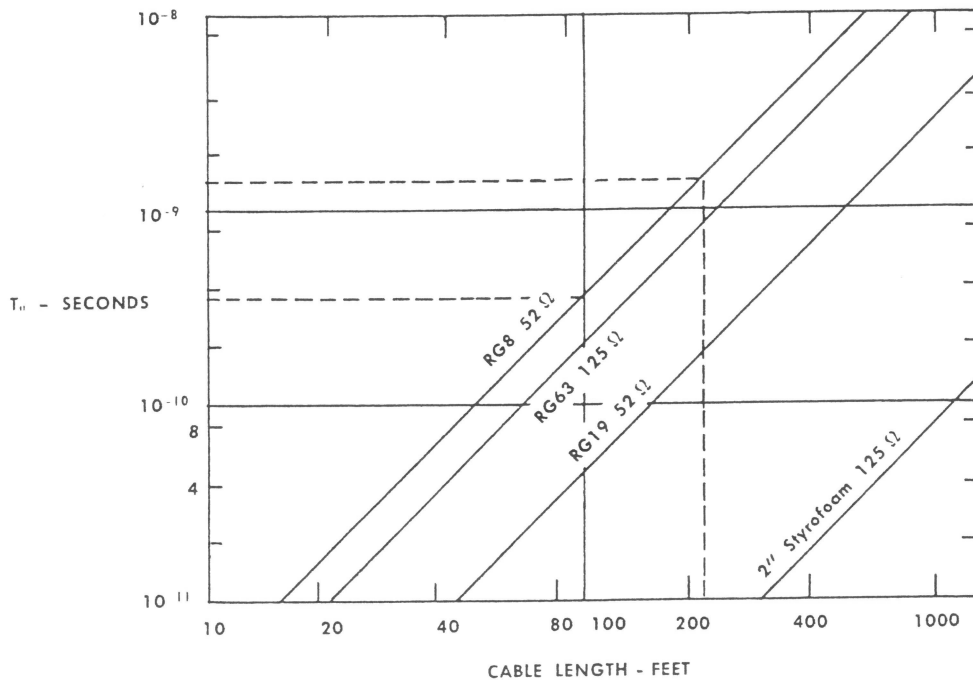

Fig. 3b. Calculated variation of  $T_0$  with cable length for typical coaxial cables. Example—100 ft. RG8,  $T_0 \cong 3.6 \times 10^{-10}$ ; 200 ft. RG8,  $T_0 \cong 1.4 \times 10^{-9}$ .

quantities are the risetime of the input pulse and imperfect terminations. The curve does not take into account the inevitable small variations of characteristic impedance along the line. The impedance variations will generally degrade the risetime of the output pulse by reflecting portions of the faster rising parts of a pulse being transmitted.

### Tektronix Sampling Systems

Two general systems of sampling are in use in Tektronix instruments. The first form, the Type N Unit, is known as

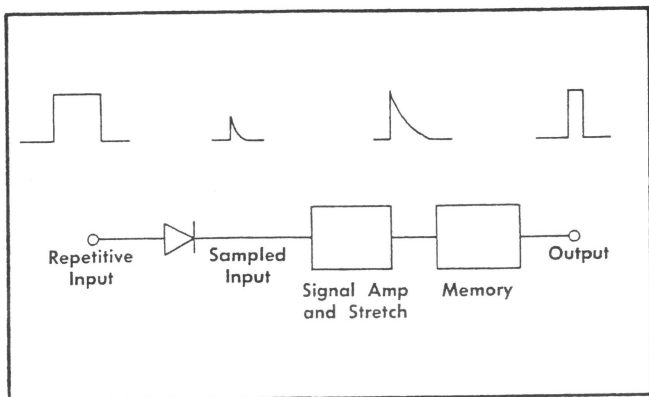

Fig. 4. Simplified block diagram of Type N Unit, an open-cycle sampled-data system.

an open-cycle sampled-data system<sup>2</sup>. See Fig. 4. The crt beam is held off the phosphor except when a sample is taken. There is no prediction of what the next sample voltage will be, nor is there any memory of the previously sampled voltage. The memory circuit resets to zero at the end of a relatively short display time.

The second form, the Type 3S76, Types 4S1, 4S2, 4S3 and 3S3, are known as an error-sampled feedback system<sup>2</sup>. The sampling circuitry employs a zero-order hold memory that remembers the amplitude of the last sample. A transition is made only when there is a change in the signal or a drift in the system. This second sampling system looks at the incoming signal, remembers it, and then only has to make a display correction for the next sample. The system can also be described as a slide-back feed-back sampling system with ratchet memory (see Fig. 5). The ratchet memory is not reset, but the display is blanked during the time of transition from one sample to the next.

The input circuit of the first system (the Type N Unit) is shown in the simplified diagram of Fig. 6. Diode D1 is normally reverse biased by the VERT. POSITION control. The signal modulates the reverse bias so that the interrogate pulse height, as fed to the stretch amplifier, varies with the signal. The stretch amplifier has a time constant long enough to effectively stretch the signal-modulated sampling-pulse to about 250 nsec. The vertical system ultimately presents a 1- $\mu$ sec pulse to the oscilloscope for each sample taken; then the system is reset to zero, ready for the next sample.

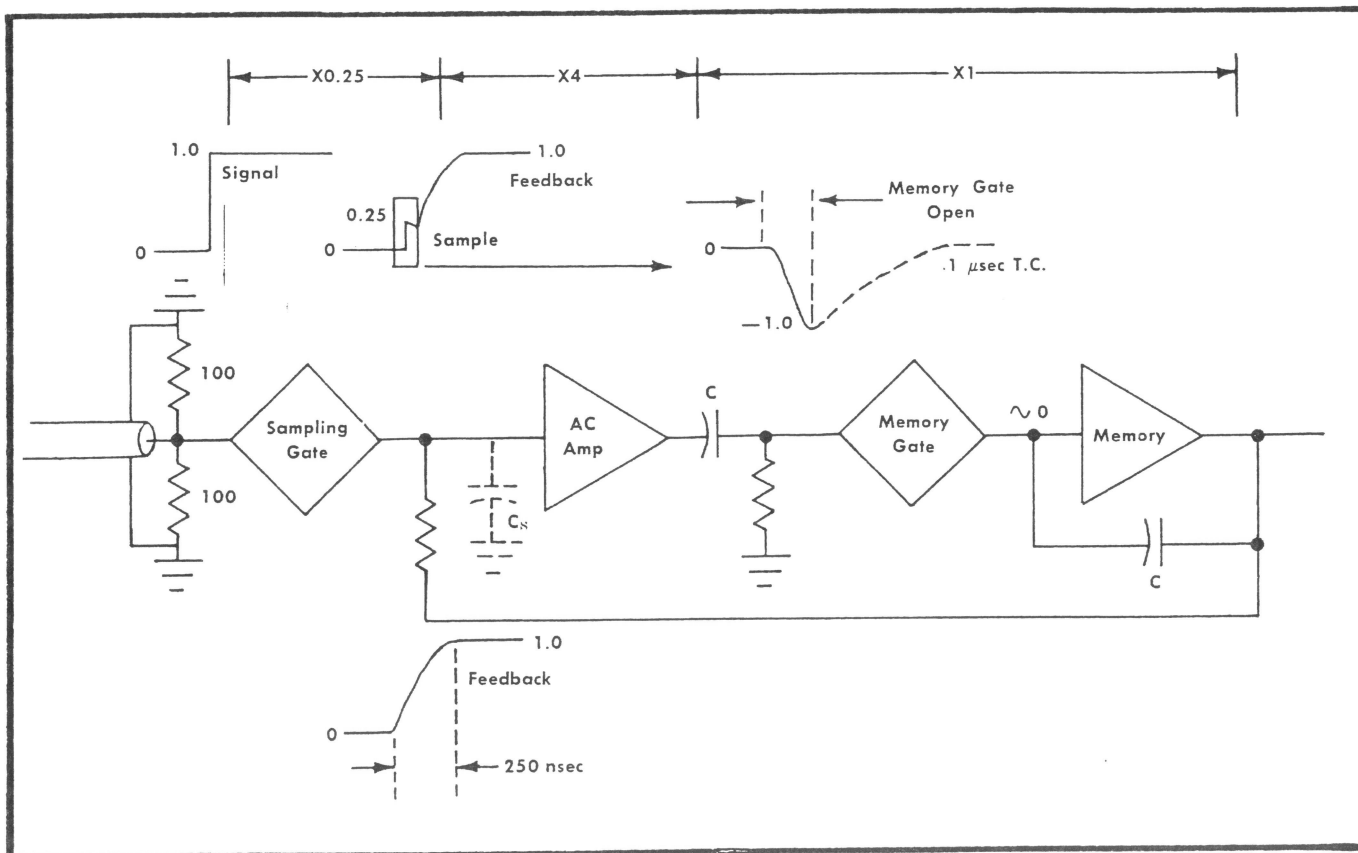

Fig. 5. Tektronix slide-back feed-back sampling system.

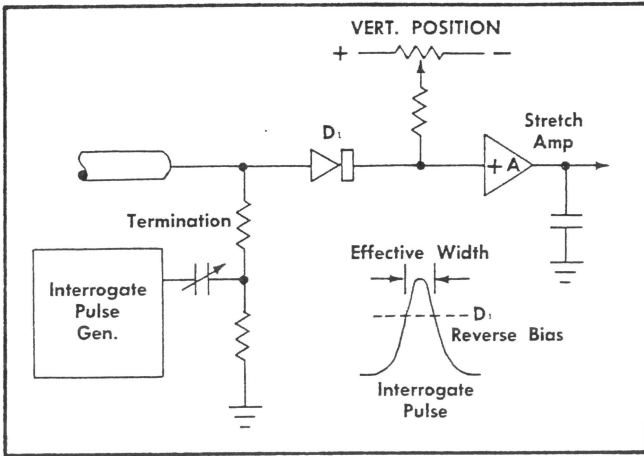

Fig. 6. Simplified Type N input circuit.

The input circuit of the slide-back feed-back sampling system is presented in simplified form in Fig. 7. The sampling bridge type gate is held reverse biased except during the short interrogate pulse duration. Reverse biasing the gate prevents the signal from being passed to the first amplifier. If the sampling gate is a balanced system, the interrogate pulse forward biases the gate and permits the signal to pass, without the amplifier or input system seeing the pulse. The balanced bridge sampling system operates with less noise and better linearity than the single diode open-loop system.

When the sampling gate passes the signal, C<sub>1</sub> starts to charge. C<sub>1</sub> charges to a fraction (such as 25% in the Type 4S1) of the difference between the signal and feedback voltages at the time of a sample. Fig. 8 is an equivalent circuit of the sampling input at the time the gate is forward biased. C<sub>1</sub> is stray and input capacity at the grid of the input amplifier. The equivalent circuit shows a group of impedances in

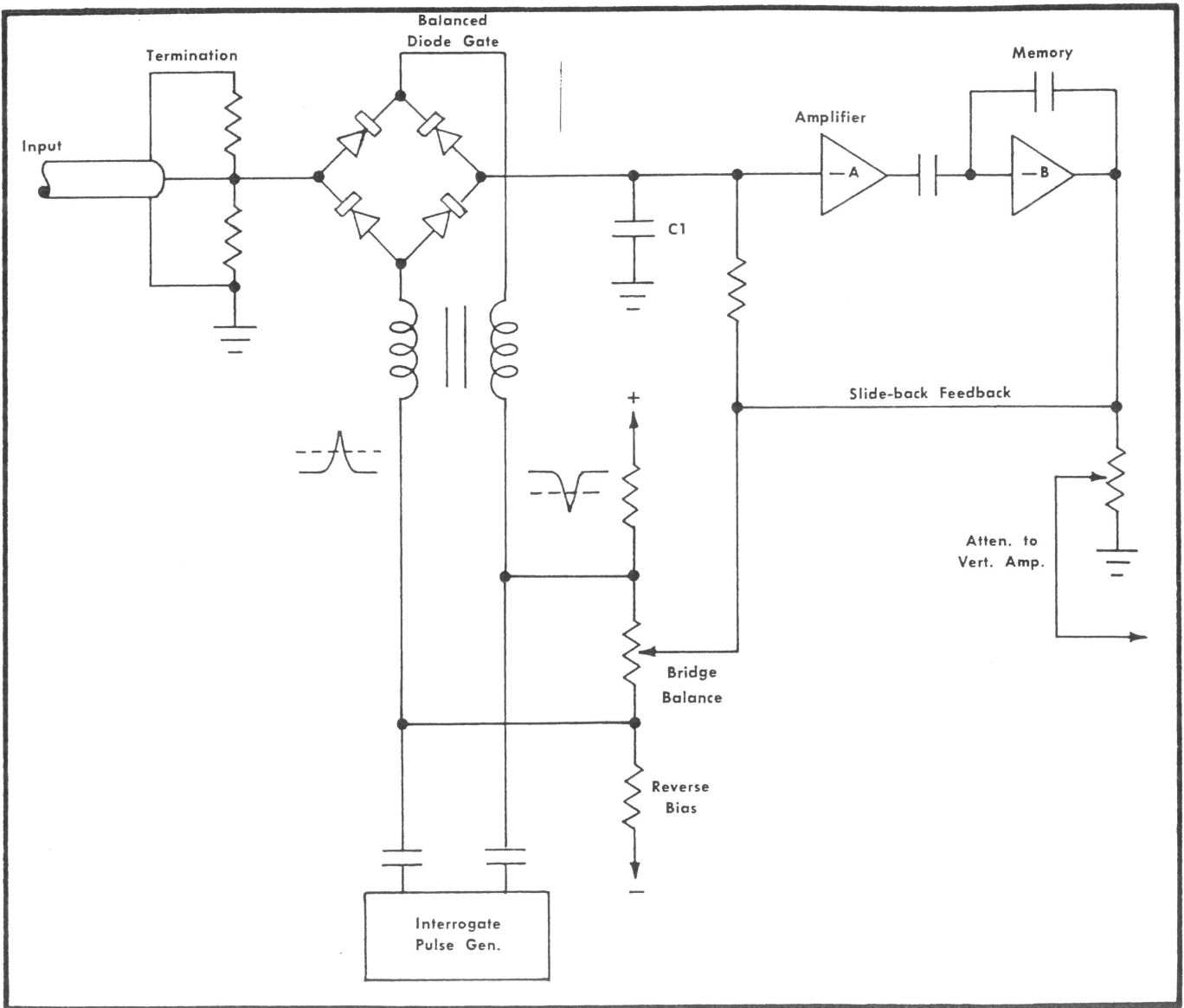

Fig. 7. Basic 50-ohm input of some Tektronix '3' and '4' Series sampling units.

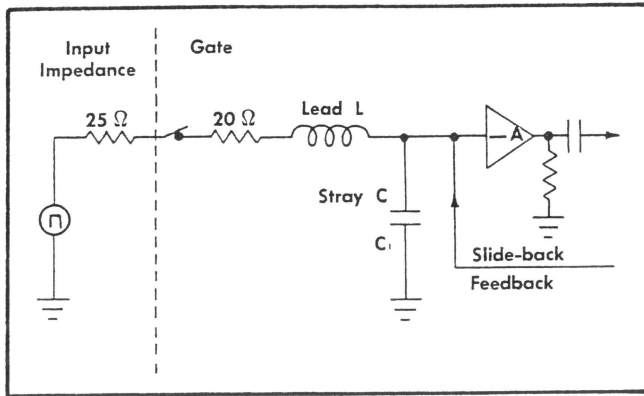

Fig. 8. 50-ohm '3' and '4' Series sampling input equivalent circuit.

series. The impulse speed of the equivalent circuit is slower than the interrogate time, thus the input signal cannot be fully impressed upon the amplifier grid. Since only 25% of the difference signal appears at the input grid, the system is said to have a 25% sampling efficiency. The amplifier and memory circuits of Fig. 7 make up the difference in signal amplitude and feed back the correct voltage so the input bridge and C1 rest at the value of the signal during interrogation. By applying feedback to the bridge, the error signal is kept to a reasonable minimum, thus keeping the interrogate pulse kickback into the input cable very small. Fig. 5 illustrates how the sampling input amplitude is brought up to the true value of the input signal by the amplifier and memory circuits.

The memory gate connects the memory circuit only long enough to respond to the amplified 25% sample signal, then disconnects it. This prevents the memory from also responding to its own feedback signal.

Fig. 9 shows the signal and feedback voltages for six samples along the rise of a step waveform.

Sample number 1. The voltage at C1 and the input are equal, so the system voltage remains at zero.

Sample number 2. The sampled voltage equals 0.25 volt. C1 charges to 25% of the difference between the sampled voltage and the voltage at C1 or 0.0625 volt, then the feedback brings the voltage up to the sampled voltage true value of 0.25 volt.

Sample number 3. The voltage difference between the sampled voltage of 0.5 volt and C1 is again 0.25 volt. Again the charge of C1 changes 25% of the difference, and the feedback raises the voltage of C1 to 0.5 volt.

This process continues until sample number 6. There is no change in input voltage between sample number 5 and sample number 6, therefore, there is no difference between the charge of C1 and the sampled voltage. The system remains at a constant voltage.

### Risetime Controlled By Interrogate Pulse Duration

The length of time a sampling bridge is forward biased and connects the signal to C1 directly controls the minimum pulse risetime a sampling system can display. The duration of the bridge forward bias is controlled by the length of

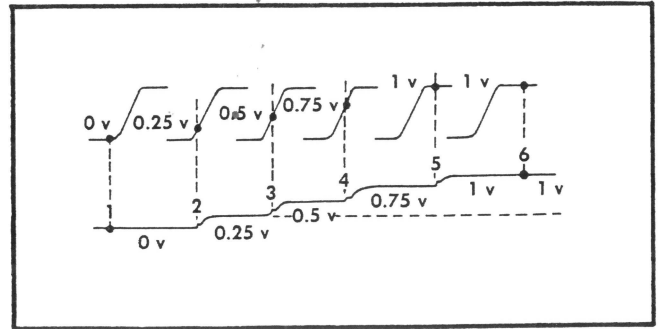

Fig. 9. Voltage changes at C1 of Fig. 8 as samples are taken. The above is true only when the loop gain is 1.

time the interrogate pulse breaks through the reverse bias. Thus sampling systems use special circuitry to make the interrogate pulse duration as short as is consistent with noise and diode recovery time. The interrogate pulse in some Tektronix slide-back feed-back sampling systems is produced by a snap-off diode and a short clip-line. The effective pulse duration is then adjusted by controlling the peak value of the pulse that is allowed to forward bias the sampling gate. Fig. 7 shows graphically how the interrogate pulse breaks through the sampling gate reverse bias. The reverse bias voltage is shown by dashed lines through the interrogate pulses. The sampling time is altered by changing the reverse bias on the sampling diodes<sup>2</sup>.

### Loop Gain

Loop gain refers to the product of the sampling efficiency and the amplifier and memory gains. The loop gain equals 1 when the voltage of C1 (Fig. 7), after memory feedback, is equal to the sampled voltage.

The loop gain of a closed-loop sampling system can be altered by changing the input amplifier gain, the duration of the interrogate pulse, or the input impedance into the sampling gate. Changing the latter two alters the sampling efficiency and thus the loop gain.

### Sampling Density

The number of samples taken per unit equivalent time is called the sampling density. For example: when the sweep rate is 10 nsec/div and when taking 100 samples per division, the equivalent time interval between dots is 0.1 nsec. This permits the system to measure time by counting the number of dots, such as is done by a digital unit.

### Dot Transient Response (Apparent Risettime Sampling Density Dependence)

When the loop gain is adjusted to be other than 1, the appearance and measured risetime of an input signal will vary with changes in sampling density. This is usually true for low sampling densities. When the display is altered by changing the samples per division, it is referred to as dot transient response error. A good test for such false displays is to change the sampling density by changing the number of samples per division on the crt by a factor of two or more. If the equivalent wave shape does not change significantly, the dot transient response is good enough.

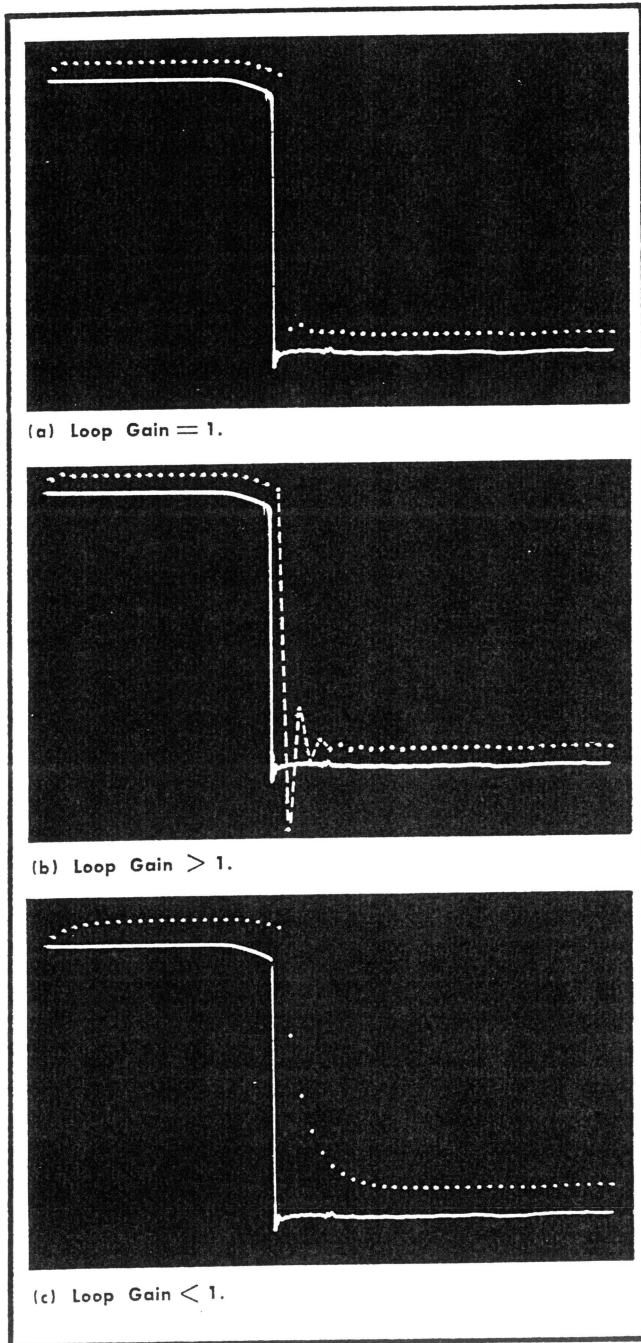

Fig. 10. Dot transient response changes with changes in loop gain.

Fig. 10 shows three conditions of loop gain vs two conditions of sampling density. In the illustration, solid traces show over 1000 samples per equivalent unit of time, and the dot traces show about 10 samples per equivalent unit of time. Note that with high sampling density the dot transient response errors are indiscernible. Fig. 10(a) shows a loop gain of 1. Changing sampling density does not significantly change apparent risetime. Fig. 10(b) shows a loop gain greater than 1. High sampling density shows the same risetime as (a), while low sampling density shows alternate overshoot and undershoot. Fig. 10(c) shows a loop gain less than 1. High sampling density shows correct risetime,

while a low sampling density shows an increased (longer) risetime. The significance of this is the loop gain can be in error by a large factor, and yet the display will be calibrated, provided there is high dot density and correctly triggered sampling.

### Smoothing Of Random Noise

The dot transient response discussion shows that with a high sampling density the loop gain can be less than 1 without degrading the display significantly. If you reduce the loop gain 50%, the display dots will move only one half the normal amount. Noise spikes will be reduced one half. Thus, while using a sampling system at high sensitivities, if random noise is apparent, reducing the loop gain can improve the display. Note that this is true only for random noise, and not for systematic noise, since systematic (repetitive) noise is looked at as being part of the signal.

Tektronix slide-back feedback sampling units have a loop gain control called SMOOTHING. Full smoothing reduces random noise typically 3 or 4 times. Always check that there is sufficient dot density to warrant the degree of smoothing used by changing the dot/division control.

### Changing Sensitivity

Fig. 11 illustrates a method used to change the overall input to memory output gain while maintaining a sensibly constant dot transient response. If the system is at maximum sensitivity, the ac amplifier is set for maximum gain and there is maximum attenuation of the feedback. This allows the memory output to be at a standard level (so many millivolts per division) for a given small input, while sending just the right amount of feedback to the input stage. To reduce system sensitivity, some attenuation is inserted in the ac amplifier. Now the memory output will be at the standard level with a larger input, and therefore the feedback must be a larger feedback to the input amplifier. Thus the system loop gain remains constant with changes in sensitivity.

### Adding a Dc Offset Voltage To The Signal

Since the sampling bridge can operate linearly with signals from  $\pm 1$  to  $\pm 2$  volts depending upon the unit in use, it is possible to view portions of a fairly large signal at high sensitivity. To bring the desired portion of the large off-screen signal into view, a dc offset voltage is added to the feedback circuit. Fig. 12 shows the general form of a signal offset voltage circuit, designed to permit changing the feedback attenuation without shifting the display up or down. With this system, any portion of a pulse can be viewed with sensitivities up to about 2 mv/cm.

### Getting The Signal To The Input

Sampling system input circuits range from 50-ohm coaxial to high-impedance probes. Each has its own advantages, and none is best for all applications.

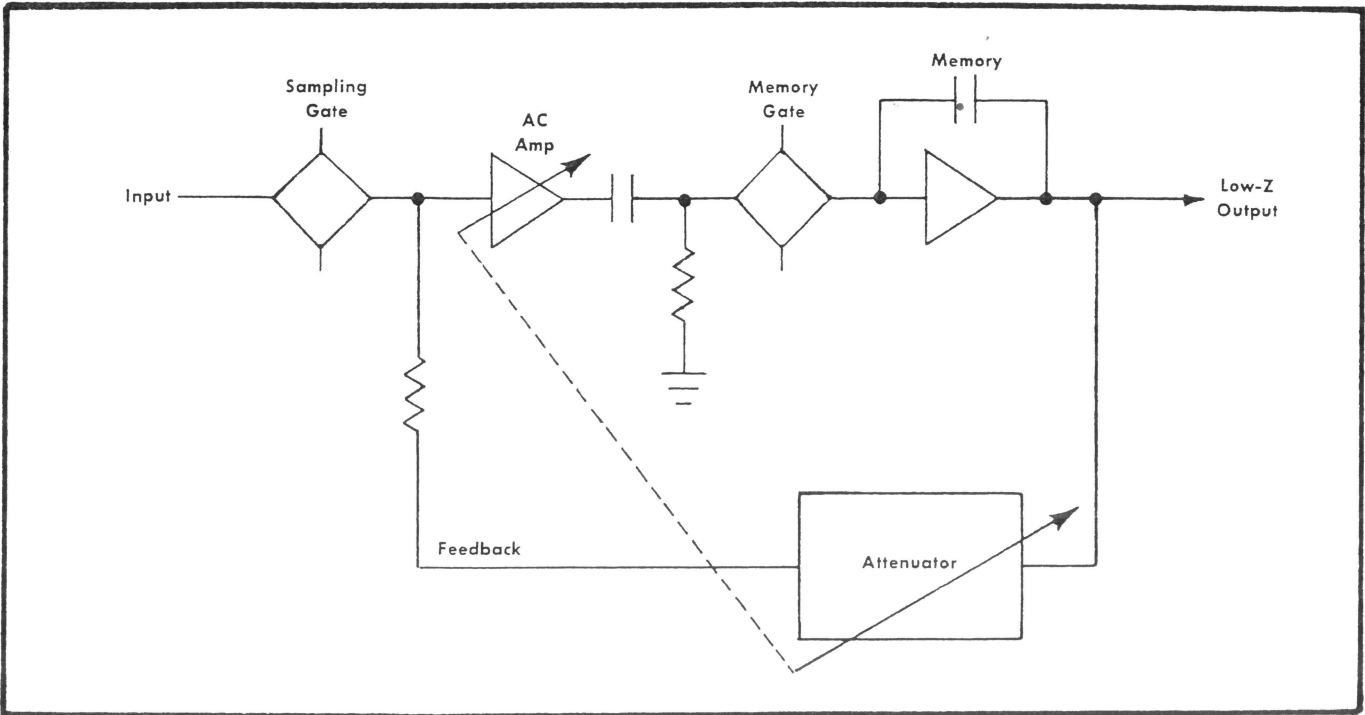

Fig. 11. Addition of an attenuator system.

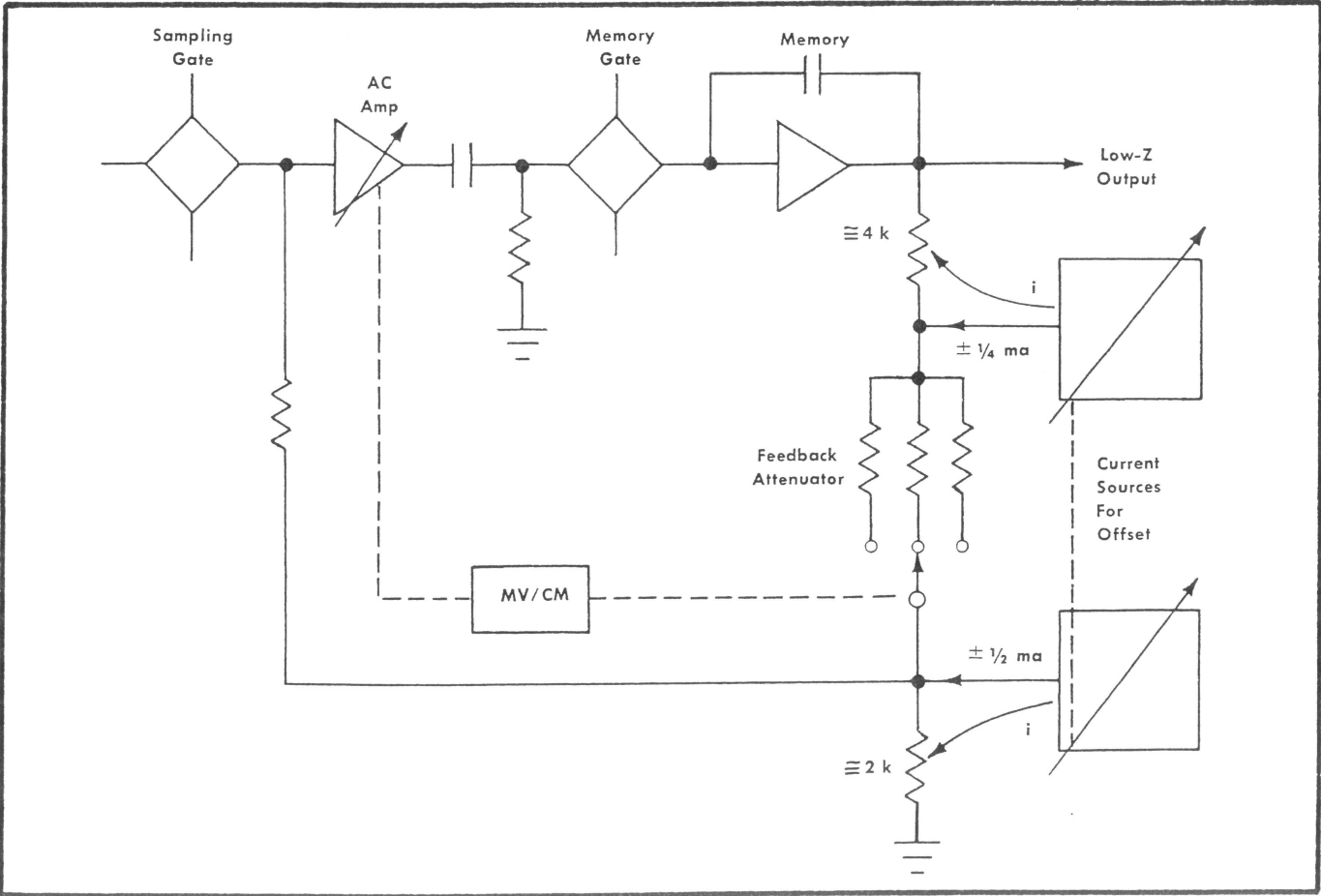

Fig. 12. Addition of a signal dc offset voltage.

## Sampling Notes

### Probes For Sampling Systems

Attenuator probes currently available for 50-ohm sampling systems include both passive and cathode follower types having input characteristics ranging from 500 ohms and 0.8 pf capacitance, to 10 megohms at dc and 1.3 to 3.6 pf capacitance. Each probe is analyzed for both resistive and capacitive input, with data shown in Fig. 13.<sup>3</sup> A combination of the Type 4S2 Dual Trace Sampling Unit and the miniature P6034 Probe (not in Fig. 13) has an upper frequency 3bd point of 3500 mc and a risetime of 100 picoseconds or less from a 25-ohm source.

Miniature probes for direct sampling systems have less obvious limitations than passive and cathode follower probes.<sup>3</sup> Signal generator impedance affects the direct sampling probe by altering the system loop gain. This however, need not be a great problem since nanosecond circuits rarely exist in high-impedance form. Source impedance sensitivity can usually be no problem in Tektronix slide-back feedback sampling systems that have the ability to operate with a high sampling density.

The Tektronix P6038 Direct Sampling Probe can be used to signal trace directly within a test circuit or can be inserted into special chassis or coaxial fittings.

The P6038 Probe can be compared with any standard oscilloscope probe. The bandwidth (risetime) is limited by internal circuitry, and by the source resistance—input capacitance time constant. The P6038 input resistance is 100 K at low frequencies, with a quite low (nominally 2 pf) input capacitance, allowing very fast response to low-impedance signals.

The major difference between the P6038 and standard attenuator probe is the sampling circuit. A small signal is sent out of the probe tip to the signal source at each sample. This can be reduced by a factor of ten by using the 10X Attenuator supplied. Normal sampling-pulse kickout (system at equilibrium) is less than 50 mv, and less than 5 mv with the 10X Attenuator. The kickout is not seen by the sampling system, and if more than about 1/3-nsec delay cable is used between the signal source and the probe tip, the kickout is not seen by the source until after the next sample is taken.

### Sampling Timing Systems

The following discussion about sampling horizontal (timing) systems outlines the systems typical of the Tektronix '3' and '5' series plug-in units.

To recreate a waveform using sampling techniques, samples must be taken over the entire waveform. Taking a sample of the leading edge of the waveform is easy; a trigger circuit is used to trip an interrogate (strobe) pulse generator directly. A block diagram of this system is shown in Fig. 14.

In practice, the system represented by Fig. 14 would not be able to sample on the very front of the waveform, because of the finite time delay in the trigger and strobe generator circuits. Therefore, a time delay must be introduced between the vertical signal input and the sampling circuit. If the vertical signal input is 50 Ω, a 50 Ω coax cable may be used to obtain the necessary delay. A delay of approximately 50 nanoseconds (solid polyethylene dielectric representing about 33 feet of 50 Ω coax), is generally used. See Fig. 15.

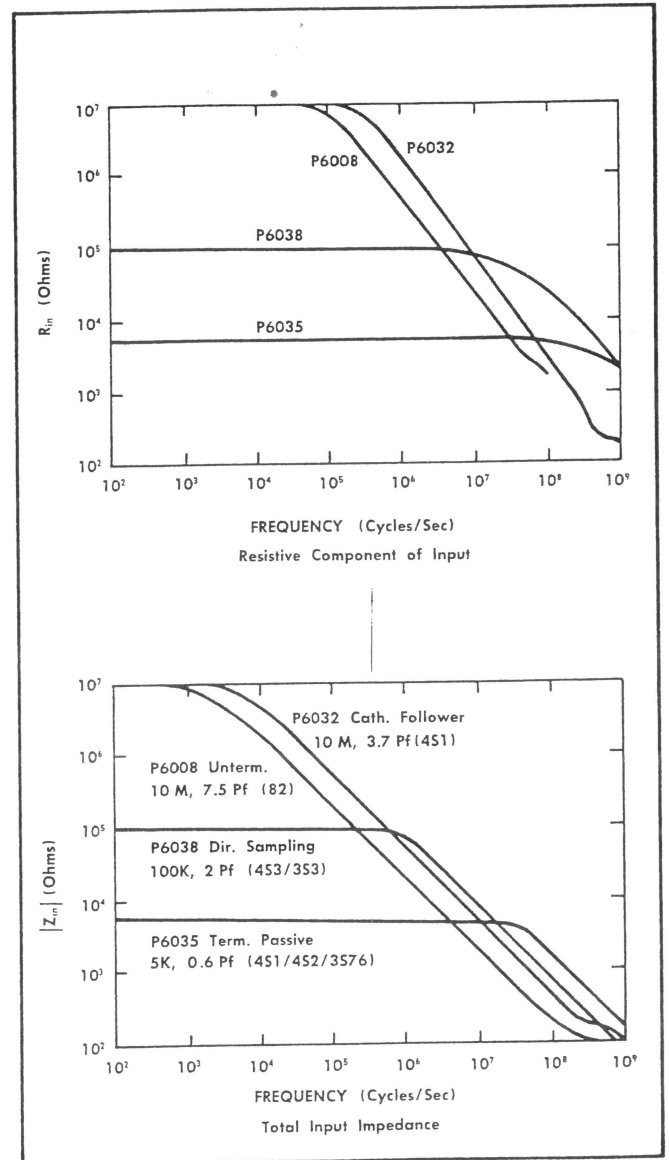

Fig. 13. Input resistance and impedance of Tektronix probes suitable for use with sampling systems.

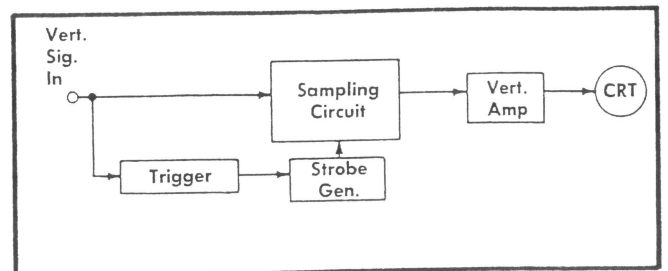

Fig. 14. Simple trigger system.



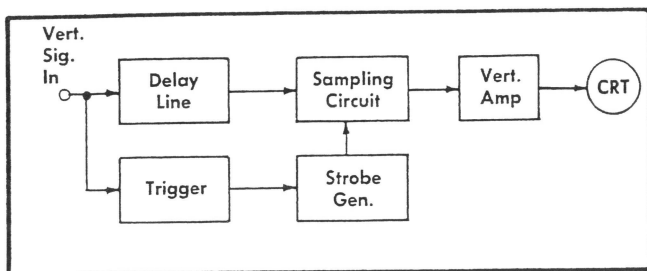

Fig. 15. Simple trigger system with signal delay so leading edge can be viewed.

Although the system represented by Fig. 15 would be able to sample on the leading edge of an incoming waveform, it probably would not be able to sample in the middle of the waveform or at the trailing edge. Practical trigger circuits can generally "recognize" only the leading edge (or transition) of a waveform. In order to sample in the middle of the waveform, a time delay must be inserted between the trigger circuit and the strobe generator.

Since long-time delays may be necessary (up to a millisecond), and since the delay should be continuously variable, an electronic delay is used. The strobe generator is now tripped by the delayed trigger output of the variable delay circuit. If a sufficient range of delay is available, samples may now be taken over the entire waveform. See Fig. 16. Fig. 17 is the Type N Unit.

Functionally, the variable delay circuit is identical to the delayed trigger pick-off in the Tektronix Type 535 Oscilloscope. The trigger circuit recognizes the incoming waveform and initiates a voltage ramp or sweep. The voltage ramp is fed into a comparison circuit, or comparator, along with a dc voltage. When the ramp reaches the level of the dc voltage, the comparator puts out a trigger pulse called the delayed trigger. The time delay between the trigger input and the delayed trigger output may be changed by varying either the dc voltage or the slope of the ramp.

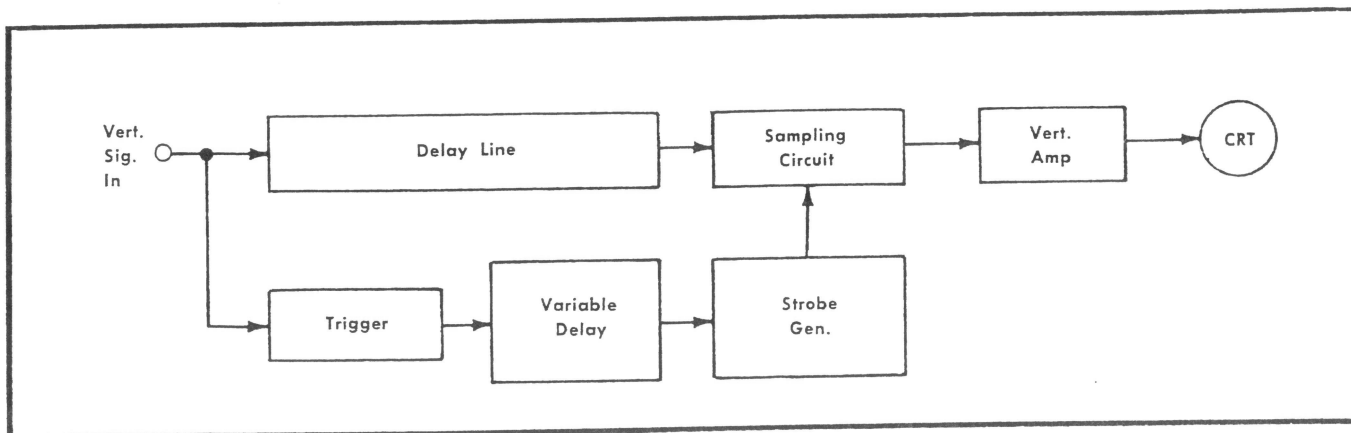

Fig. 16. Trigger system that can 'look' at leading or middle of a waveform.

Usually the dc voltage is changed to obtain a vernier delay, and the slope of the ramp is changed to change the range of the vernier. A block diagram of the delayed trigger circuit is shown in Fig. 18.

The delays needed in sampling systems are generally much shorter than those available from the delayed trigger of a Type 535; therefore, the circuitry is different. However, a voltage ramp, now called the "fast ramp", is still compared to a variable dc voltage to obtain the variable time delay needed to sample along the full length of a waveform. The sampling system block diagram now takes the form of Fig. 19.

If the dc voltage in Fig. 19 is increased each time a sample is taken, comparison will take place progressively further along the fast ramp. Thus, there is a progressive increase in the time delay between trigger recognition and sampling. This causes each sample to be taken on a different part of the incoming signal.

A complete sampling system, therefore, includes an incremental voltage-advancing circuit or "staircase generator". The staircase generator is made to advance one increment immediately after each sample is taken, by feeding the delayed trigger output of the comparator into the staircase generator. By advancing the staircase immediately after a sample is taken, the staircase generator is given the maximum time to reach its new dc level before the next fast ramp arrives. Substituting a staircase generator for the variable dc voltage, the block diagram changes to Fig. 20.

The *real time* spacing is determined only by the repetition rate of the signal (up to the maximum sampling rate of the oscilloscope). The *equivalent time* spacing is determined only by the fast ramp slope and the amplitude of each stairstep. Therefore, the *equivalent time* of a sampling display is independent of the *real time* of the display and vice-versa.

If the fast ramp is a linear voltage/time ramp and if the stairstep is advanced in uniform increments, the spacing of the samples along the incoming signal will be uniform in *equivalent time*.

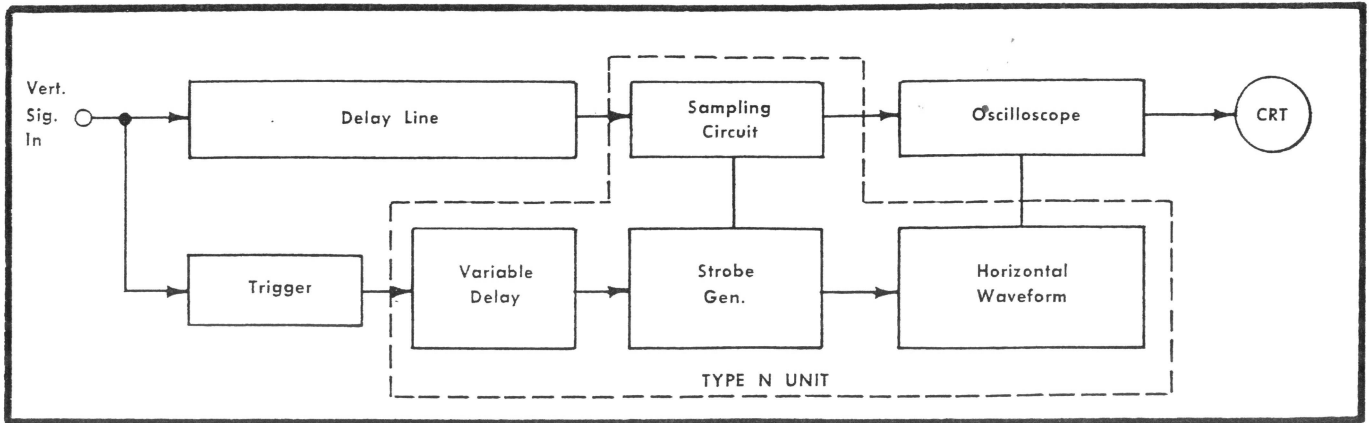

Fig. 17. Simple block diagram of Tektronix Type N Unit with external trigger system.

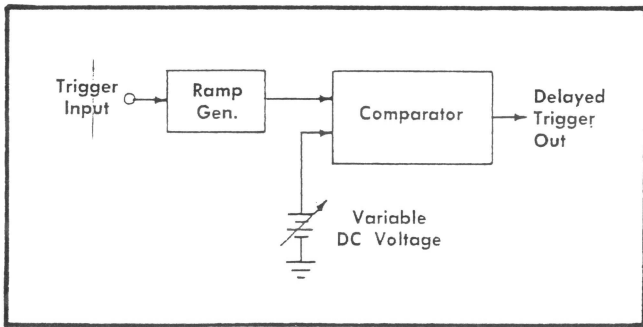

Fig. 18. Block diagram of a delayed trigger circuit.

To understand the meaning of "equivalent time", consider the following case: Recreate a repetitive pulse 12 nanoseconds wide by taking 12 samples, one sample per incoming signal. In this case, the *real time* between successive

samples depends on the repetition rate of the signal. However, by using 12 samples to reconstruct a picture of the waveform, we are in effect pretending that all of the samples were taken on one pulse. If this were true, the time between samples would be only 1 nanosecond (12 samples along the 12-nanosecond pulse). This is the *equivalent time* between samples. See Fig. 21.

To reconstruct a signal, the samples must be spaced horizontally in the proper time sequence. This is done by feeding the staircase into the horizontal amplifier so that the trace moves one increment horizontally as each sample is taken. The relationship between the increment of horizontal distance per sample and the equivalent time per sample will determine the (equivalent) sweep time/div. Adding this function, the block diagram becomes that of Fig. 22.

To take a specific example, suppose that the amplitude of staircase going into the comparator is 50 mv/step, where one step equals one sample. If the fast ramp rises 50 mv/nsec, the equivalent time per sample will be 1 nanosecond.

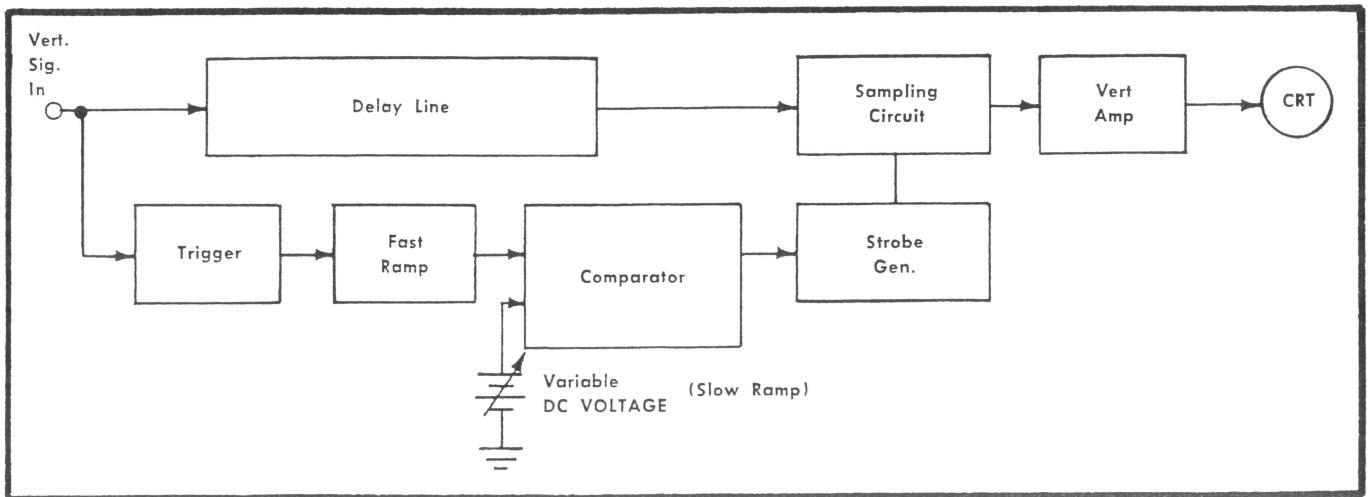

Fig. 19. Addition of a variable trigger circuit that allows triggering to progress along signal waveform.

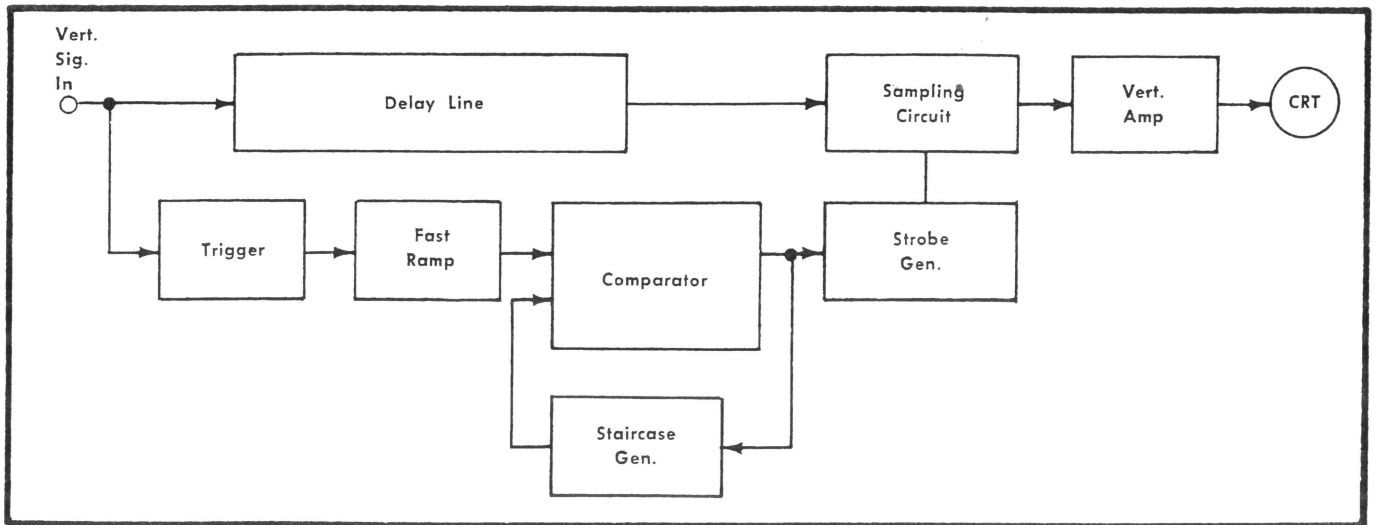

Fig. 20. An automatic variable trigger circuit.

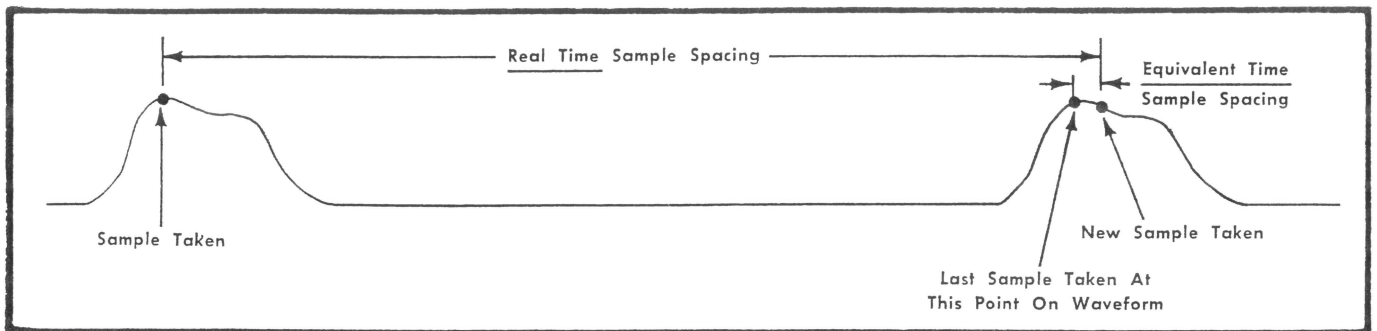

Fig. 21. Real Time and Equivalent Time relationship.

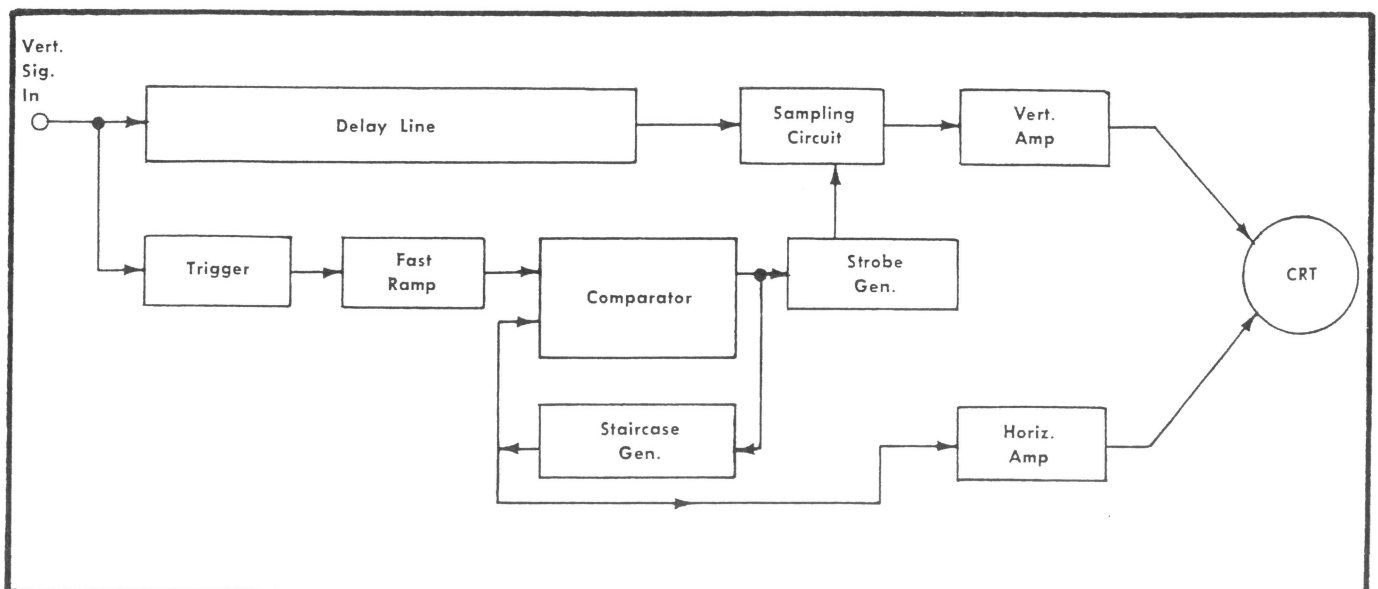

Fig. 22. Completed block diagram of the Tektronix slide-back feedback sampling systems.

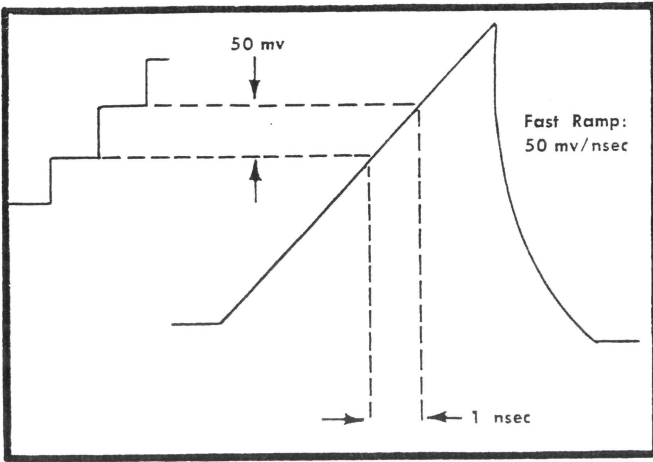

Fig. 23. Fast ramp waveform that will produce an equivalent time per sample of 1 nanosecond.

See Fig. 23. To adjust the gain of the horizontal amplifier so that each step advances the trace horizontally 1 millimeter, 10 samples (at an equivalent time per sample of 1 nanosecond) will be required per cm; the sweep time/cm, therefore, will be 10 nanoseconds. In other words, the (equivalent) time per sample, times the number of samples per division, equals the (equivalent) time per division:

$$(\text{Time/sample}) (\text{Samples/div}) = \text{Time/div.}$$

Returning to the specific example, leave the fast ramp and the horizontal gain unchanged, but change the amplitude of each stairstep from 50 mv to 100 mv. This will result in a horizontal step of 2 mm/sample or 5 sample/cm. The equivalent time/sample will increase from 1 nanosecond to 2 nanoseconds. The resulting time/cm may now be calculated:

$$(2 \text{ nsec/sample}) (5 \text{ samples/cm}) = 10 \text{ nsec/cm.}$$

Changing the amplitude of the stairstep thus does not affect the time/cm calibration of the display, provided the horizontal gain and the fast ramp slope remain unchanged. The SAMPLES/DIV. control on sampling oscilloscopes merely changes the amplitude of each step in the staircase.

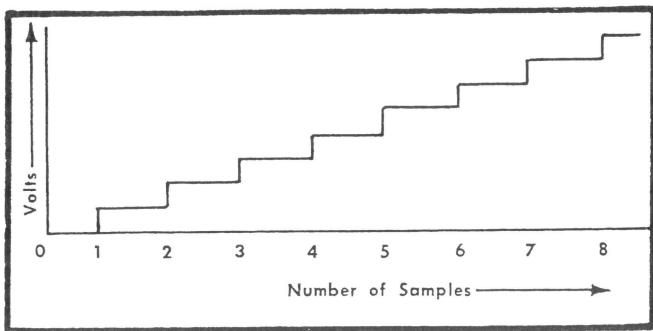

Fig. 24. Staircase voltage changes with synchronously repetitive signal sampling.

The previous discussion referred to a staircase to sample at various points along a signal (common practice is to say that the strobe pulse "slews" along the signal). Under certain conditions the stairstep waveform will not resemble its namesake very closely. Actually, the staircase advances one step per sample, so that the voltage versus the number of samples taken looks like Fig. 24. If the incoming signal repeats at regular intervals, the spacing of the steps on the staircase will be uniform in real time, as shown in Fig. 24.

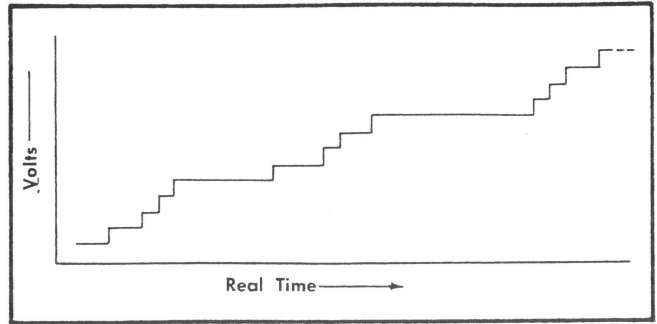

Fig. 25. Staircase voltage changes with irregular repetitive signal sampling.

However, if the incoming signal recurs at an irregular rate, the spacing of the samples (and steps) will be nonlinear in real time as shown in Fig. 25.

Therefore, do not expect the stairstep to always look like a uniform stairstep when observed in *real time*. Note that irregular spacing of the samples in *real time* will not cause irregular spacing in *equivalent time*, since the equivalent time calibration is independent of the repetition rate of the incoming signal. Problems will arise, however, when equivalent time phenomena are viewed on a real time (conventional) oscilloscope.

References

1. Transient Analysis Of Coaxial Cables, Considering Skin Effect, Wiginton and Nahman, Proc. IRE, Vol. 4<sup>F</sup> pp 166-174. February 1957.
2. Sampled-Data Control Systems, Ragazzini and Franklin McGraw-Hill Book Co. 1958.
3. In And Out Of Circuits With Probes, Winningstad, Tektronix Publication 061-996, N.E.C. Paper. 1963